

Product Features

- Dielectrics:
Standard PTFE/ High Temp PTFE
Polypropylene
Polycarbonate
- SMD and lead-through-hole mounting
- Top, Bottom and Side Mount models
- Wide capacitance ranges
- Low cost
- Linear capacitance change vs. rotation
- Compact size

Product Applications

- Typical Applications:**
- Antennas • Transmitters
 - RF Equipment
 - Test Equipment
- Modifications & Variations:**
- Special capacitance ranges
 - Special terminal sizes & shapes
 - Extended Adjust shafts
 - High temperature versions for PTFE
 - Silver and/or Gold Plating



Part Numbering

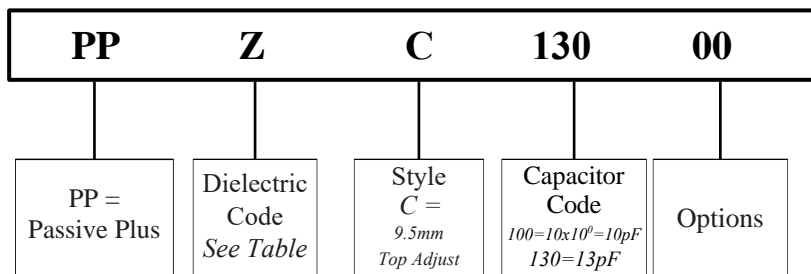

For special requests, please contact directly.

Dielectrics

Dielectrics	
Code	Description
X	PTFE (Polytetrafluoroethylene)
Y	PP (Polypropylene)
Z	PC (Polycarbonate) or PI (Polyimide)

Style

Style	
Code	Description
C	9.5mm Top/Bottom Adjust
D	9.5mm Side Adjust
F*	9.5mm Top/Bottom Adjust
T*	9.5mm Side Adjust

* Extended Temperature range: -40 to +125°C

Capacitance

Capacitance Code
2R0 = 2.0pF
400 = 40pF
151 = 150pF

Special Options

Special Options (Top Adjust Models)	
Code	Description
00	Standard
03	9.5mm, 3 lead special
04	9.5mm, 2 leads



⚡ Electrical Specifications

Dielectrics	<ul style="list-style-type: none"> • High Temperature PTFE • Standard PTFE • Polypropylene (PP) • Polycarbonate (PC)
Voltage Rating	200V High Temp PTFE 100V all other Dielectrics
Dielectric Withstanding Voltage	300V High Temp PTFE 200V all other Dielectrics
Contact Resistance	≤ 0.010mΩ
Insulation Resistance	≥ 10,000MΩ
Rotation Torque	0.15...3.5Ncm

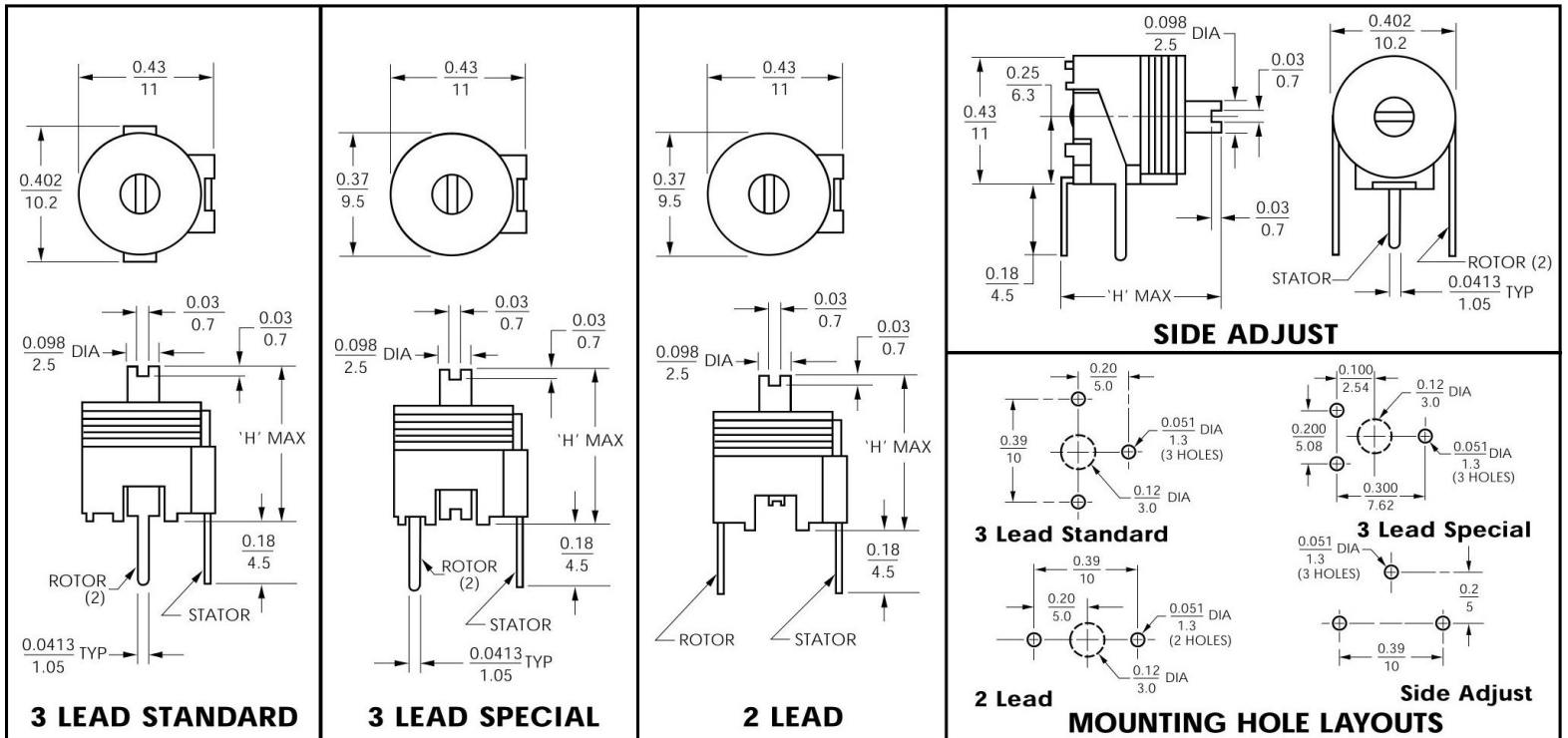

All dimensions are in/mm.



≠ General Specifications

Dielectric	Capacitance (pF)		Q min (1MHz)	TCC (ppm/°C)	Operating Temperature (°C)	H max in/mm	Color Code	Model Number			
	min	max						Top/Bottom 3 Lead	Top/Bottom 3 Lead Special	Top/Bottom 2 Lead	Side Adjust
PTFE	2.0	13		0±400		0.40/10.2	Blue	PPXC13000	PPXC13003	PPXC13004	PPXD13000
	3.0	26		0±350		0.40/10.2	Green	PPXC26000	PPXC26003	PPXC26004	PPXD26000
	3.5	38		0±300		0.40/10.2	Clear	PPXC38000	PPXC38003	PPXC38004	PPXD38000
	6.0	60	1500	0±300	-40 to +85	0.45/11.4	Yellow	PPXC60000	PPXC60003	PPXC60004	PPXD60000
	7.0	75		0±300		0.45/11.4	Red	PPXC75000	PPXC75003	PPXC75004	PPXD75000
	8.0	90		0±300		0.49/12.0	Violet	PPXC90000	PPXC90003	PPXC90004	PPXD90000
	10	150		0±300		0.49/12.0	Orange	PPXC15100	PPXC15103	PPXC15104	
PTFE High Temp	2.5	15		0±250		0.40/10.2	Red	PPXF15000	PPXF15003	PPXF15004	PPXT15000
	3.0	25		0±250		0.40/10.2	Clear	PPXF25000	PPXF25003	PPXF25004	PPXT25000
	4.0	40	1500	0±250	-40 to +125	0.40/10.2	Yellow	PPXF40000	PPXF40003	PPXF40004	PPXT40000
	5.5	60		0±250		0.45/11.4	Blue	PPXF60000	PPXF60003	PPXF60004	PPXT60000
	6.0	75		0±250		0.45/11.4	Violet	PPXF75000	PPXF75003	PPXF75004	PPXT75000
	8.0	90		0±250		0.49/12.4	Orange	PPXF90000	PPXF90003	PPXF90004	PPXT90000
PP	2.0	15		0±400		0.40/10.2	Blue	PPYC15000	PPYC15003	PPYC15004	PPYD15000
	3.0	20	1000	0±400	-40 to +70	0.40/10.2	Green	PPYC20000	PPYC20003	PPYC20004	PPYD20000
	3.5	40		0±350		0.40/10.2	Clear	PPYC40000	PPYC40003	PPYC40004	PPYD40000
	4.5	65		0±350		0.40/10.2	Yellow	PPYC65000	PPYC65003	PPYC65004	PPYD65000
PC	8.0	80		0±200		0.40/10.2	Red	PPZC80000	PPZC80003	PPZC80004	PPZD80000
	9.0	100		0±400		0.45/11.4	Violet	PPZC10100	PPZC10103	PPZC10104	PPZD10100
	9.0	120	200	0±350	-40 to +85	0.45/11.4	Orange	PPZC12100	PPZC12103	PPZC12104	PPZD12100
	10	150		0±350		0.47/12.0	Orange	PPZC15100	PPZC15103	PPZC15104	PPZD15100
	12	180		0±350		0.47/12.0	Orange	PPZC18100	PPZC18103	PPZC18104	PPZD18100

≠ Production Qualification

- FilmTrim Capacitors are in accordance with DIN IEC 418-1 and 4-former DIN 44261 part 3.
- Testing methods for manufacturing quality are in accordance with MIL- STD-105D and IEC410 (former DIN44260).
- Solderability or heat resistance for the FilmTrim Capacitors comply with DIN IEC 68-2-20 part 2, Test Ta and Tb.
- Each FilmTrim Capacitor is tested for minimum and maximum capacitance value and is also subjected to full test voltage.

≠ Specifications Notes

- 1 Parts are 100% tested for capacitance range and dielectric withstanding voltage.
- 2 Capacitance range specified is that which is guaranteed and is measured at 1 MHz at room temperature.
- 3 Q factor is measured at maximum rated capacitance and at room temperature.
- 4 Dielectric strength is measured at maximum rated capacitance and room temperature, with test voltage (as listed for each model) applied for 60 seconds.
- 5 Insulation resistance is measured at maximum rated capacitance and room temperature and at rated voltage, unless otherwise specified.
- 6 Temperature coefficient of capacitance (TCC) is measured at 1 MHz over the operating temperature range, with capacitor set at maximum rated capacitance.
- 7 Axial load during tuning should not exceed 200 grams force. At maximum axial load, capacitance change is no more than 15%.
- 8 Capacitors should not be operated outside of rated capacitance range and working voltage.

≠ Soldering FilmTrim Capacitors

Dip soldering:

260°C ± 10°C for 7 seconds maximum.

Hand Soldering

(for lead-through-hole models):

Tip temperature 350°C ± 10°C for 3 to 4 seconds



≠ Cleaning FilmTrim Capacitors

Water soluble fluxes and detergents with a

- 1 water flush after soldering of the boards can be used for all parts.

Do not immerse FilmTrim models in chlorinated or fluorinated hydrocarbon solvents as this would adversely affect the plastic dielectrics and base materials.

- 2 Some customers have successfully used X models in scrubbers or sprayers where only bottom of the printed circuit boards is exposed to solvents.

If the process requires immersion in solvents for cleaning boards, the FilmTrim capacitors should be hand soldered to board after the boards have been cleaned.